

SPECIFICATIONS

Air Pilot Operated Hydraulic Spool Valve.
 Four Way, Directional Control or Selector Valve.
 Maximum System Pressure:
 Parts A, B, P, and T rated to 3,000 PSI.
 Maximum Pilot Pressure (X port) 150 PSI.
 Fluid temperature -40°F (-40°C) to 200°F (93.3°C)
 Install Cartridge Valve using No. 471 Spanner Tool.
 Valve should screw in freely to the Mount Seal.
 Final tightening to 15 foot pounds torque.
 Use lubricant on external oil seals and mounting threads.

OPTIONS

Pilot Port (Key X) is 1/8 NPT.
 Optional Pilot Porting includes 1/4 NPT, SAE4, and SAE6.
 Standard seals are Buna-N with Teflon back up rings.
 Optional seals include Viton, Teflon and others.
 Keys 7 & 20 are vents to atmosphere.
 T Option provides 10-32 Threaded parts at these locations.

TOOLING

Cavity Form Tool: FT-8544
 * 1/8 (3.175) Pin Spanner Tool
 Order No. 471
 * 3/16 (4.763) Face Spanner Tool
 Order No. 482

PILOT RATIO NOTES:

- TO CALCULATE THE CORRECT PILOT RATIO VALVE TO ORDER FOLLOW THESE STEPS:
- Determine the MAXIMUM possible system pressure.
 Multiply X 11 = SYSTEM
 - Determine MINIMUM possible pilot pressure.
 Multiply X .9 = PILOT
 - Divide SYSTEM by PILOT = PILOT TO SYSTEM RATIO
 - Round up to standard available ratio.

CARTRIDGE VALVE

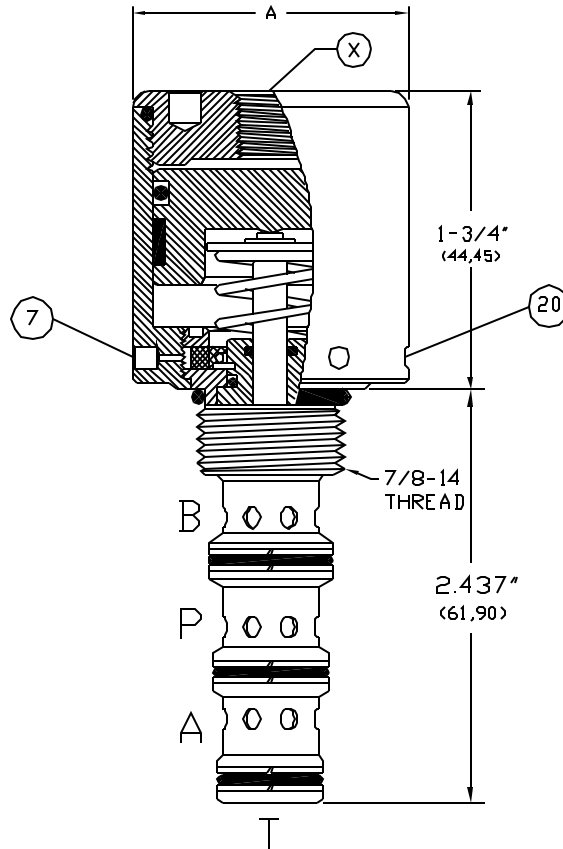

Cartridge Valve Requires Cavity C-8544

HOUSING

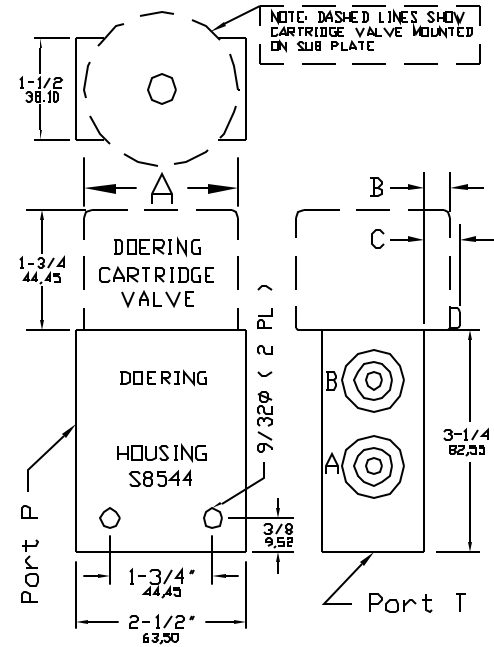

Housing Parts A, B, P & T: P/N S8544 are 3/8 NPT,
 P/N S8544-2 are 1/4 NPT, P/N S8544-6 are SAE6.
 Standard Housing material is Aluminum.
 For Stainless order S8544-3 or S8544-2S or S8544-6S

PRESSURE DROP CHART

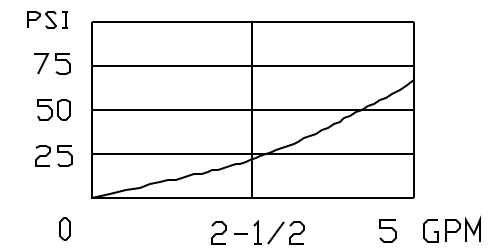

PILOT TO SYSTEM RATIO	" A " DIAMETER	" B " MAXIMUM	" C " MAXIMUM APPLICABLE TO T OPTION ONLY	CARTRIDGE VALVE NO.	HOUSING BODY NO.	FUNCTIONAL SYMBOL
108:1	1-1/2 (38.1)	NOT APPLICABLE	.15 (3.8)	442371084	S8544	<p>USE THIS SPOOL FOR LOWEST LEAK RATE.</p>
131:1	1-5/8 (41.28)	.06 (1.6)	.21 (5.4)	443371314	- OR - S8544-2	
183:1	1-7/8 (47.63)	.19 (4.8)	.34 (8.6)	446371834	- OR -	
277:1	2-1/4 (57.15)	.38 (9.6)	.53 (13.5)	447372774	S8544-6	
108:1	1-1/2 (38.1)	NOT APPLICABLE	.15 (3.8)	442371085	S8544	
131:1	1-5/8 (41.28)	.06 (1.6)	.21 (5.4)	443371315	- OR - S8544-2	
183:1	1-7/8 (47.63)	.19 (4.8)	.34 (8.6)	446361835	- OR -	
277:1	2-1/4 (57.15)	.38 (9.6)	.53 (13.5)	447372775	S8544-6	

4PS SERIES

4 Way Spool Valve, Pilot Operated.
 Directional Control or Selector Valve.