

KEY EXPLANATION:

1. Port No. 1, System
2. Port No. 2, System
3. Poppet, Check, Hard Stainless
4. Poppet Check Spring, Stainless Steel
5. O-Ring Seal, Buna N (Also See Options)
6. Filter, 10 Micron, Sintered Bronze
7. Vent (2 Pl.) Optional T Port Locations
8. Filter Retainer
9. Actuator Return Spring, Stainless Steel
10. Piston Guide Ring
11. Piston O-Ring Seal, Buna N (Also See Options)
12. Bonnet O-Ring Seal, Buna N (Also See Options)
13. 3/16" (4.763) Spanner Holes (2 Pl.)
14. 1/8 NPT Pilot Port X (Also See Options)
15. Bonnet, Aluminum material
16. Actuator Body, Aluminum
17. Actuator Piston, Aluminum
18. Push Rod, Hard Stainless Steel
19. Push Rod Seal, Teflon
20. 1/8" (3.175) Spanner Holes (4 or 6 Pl.)
21. Cartridge Seat Retaining Ring
22. Mount O-Ring Seal, Buna N (Also See Options)
23. 7/8-14 Cartridge Mounting Threads, Stainless Steel
24. Cartridge Seat, Hard Stainless
25. Back Up Ring, Teflon
26. O-Ring Seal, Buna N (Also See Options)
27. Spring (Used on valves = "A" Dia. 1-7/8 & 2-1/4")

SPECIFICATIONS:

Pilot Operated Check Valve.
 Flow is checked from port 1 to port 2.
 Add Seat Crack pressure for flow from 2 to 1.
 Piloting valve allows free flow in both directions.
 Maximum pressure at Ports 1 and 2 is 5,000 PSI.
 Pilot Pressure Range, 50 PSI Min. to 150 PSI Max.
 Fluid temperature -45°F, (42.7°C) to 200°F, (93.3°C)
 Install Cartridge valve using 1" wrench
 Valve should screw in freely to the Mount Seal.
 Final tightening to 20 foot pounds torque.
 Use lubricant on external oil seals and mounting threads.

PILOT RATIO NOTES:

TO CALCULATE THE CORRECT PILOT RATIO VALVE,
 FOLLOW THESE STEPS:

1. Determine the MAXIMUM possible system pressure.
 Multiply X 1.1 = SYSTEM
2. Determine MINIMUM possible pilot pressure.
 Multiply X .9 = PILOT
3. Divide SYSTEM by PILOT = PILOT TO SYSTEM RATIO
4. Round up to standard available ratio.

CARTRIDGE VALVE

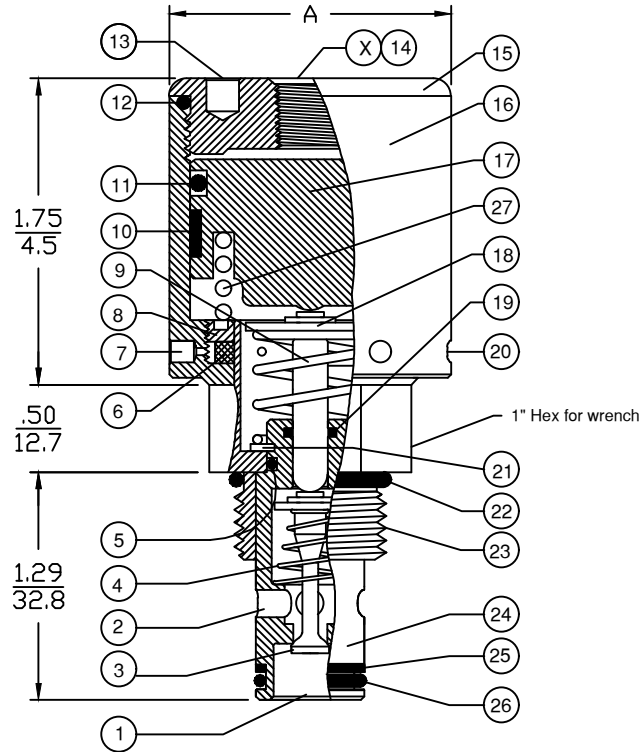

INCH
 METRIC

STANDARD OPTIONS

Pilot Port (Key X) 1/8 NPT. Optional SAE4 Available.
 Seals: Buna N, Viton or Teflon. Others please specify.
 T Option: 10-32 Ports at Key 7 & 20, Random 360° Pos.

TOOLING

- * 1/8 (3.175) Pin Spanner Tool
 Order No. 471, Ref. Key No. 20
- * 3/16 (4.763) Face Spanner Tool
 Order No. 482, Ref. Key No. 13

Cavity & Housing

Please see Spec. Sheets
 at www.doering.com

Cavity C-8542 (10-2):
 See Spec. Sheet 1200621
 Includes Cavity and
 Cavity Tooling Info.

Line Mount Housings:
 See Spec. Sheets
 1200674 and 1201455

Panel Mount Housings:
 See Spec. Sheets
 1202982 and 1202990

Two Stage
 Decompression Housings:
 See Spec. Sheets
 1201268 and 1203114

PILOT TO
 SYSTEM RATIO

" A "
 DIAMETER

ORDER VALVE NUMBER:

FLOW AND PRESSURE
 DROP CHARTS

POC SERIES

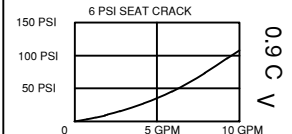
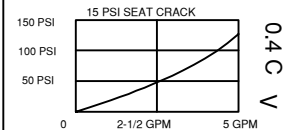
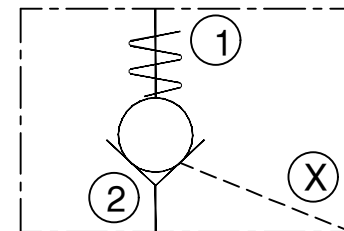

6343 RIVER ROAD SE ■ CLEAR LAKE, MN 55319 USA
 Telephone: 320-743-2276 ■ Fax: 320-743-3723
mailbox@doering.com ■ www.doering.com



DOERING